

modern + ICE



Brio[®]

Point-of-Use Water Cooler
& Ice Dispenser

User's Manual
Model: CLPOU720UVRO4IC

Table of Contents

Safety Information	2
Intended Use	3
Product Features	3
Touch Panel Description	4
Operational and Technical Specifications	4
Package Contents	5
Materials Needed	5
Installation	5
Determine Installation Location	5
Install Drip Tray and Grid	5
Connect to the Cold Water Supply	6
Make the Reverse Osmosis Waste Connections	7
Flush the Filters	8
Install the Filters and Complete the Installation	9
Using the Dispenser	9
Turn the Dispenser On/Off	9
Set the Time	10
Dispense Ice	10
Dispense Cold Water	10
Dispense Hot Water	10
Cleaning and Maintenance	11
Clean the Reservoirs	11
Filter Replacement Schedule	13
Replace the Filters	14
Filter Specifications	14
Care and Maintenance	15
Troubleshooting	15
Warranty	16

Safety Information

- WARNING:** To reduce risk of injury and property damage, you must read this entire guide before assembling, installing, and operating dispenser.
- WARNING:** WATER DISPENSER IS HEAVY. TWO PERSON LIFT REQUIRED. Use two or more people to move and install unit. Failure to do so can result in back or other injury.
- WARNING:** HOT WATER. Unit produces Hot Water in excess of 80° C (175° F). Water above 52°C (125° F) can cause severe burns or scolding. Keep unauthorized people and children away from the unit to avoid accidental dispensing of hot water.
- WARNING:** ELECTRIC SHOCK HAZARD. To reduce the risk of fire, electric shock, or injury when using your water cooler, follow these precautions:
- Plug into a 3-prong outlet.
 - DO NOT use an extension cord.
 - DO NOT remove ground prong.
 - Disconnect the power before servicing.
 - DO NOT use an adapter.
 - Replace all the parts and panels before operating.
- Failure to follow these instructions can result in death, fire or electrical shock.
- Prior to use, this dispenser must be properly assembled and installed in accordance with this manual.
 - This dispenser is intended for water dispensing only. DO NOT use with other liquids or for purposes for which it was not intended.
 - Use only known and microbiologically safe water.
 - For indoor use only. Keep water dispenser in a dry place away from direct sunlight. DO NOT use outdoors.
 - Install and use only on a hard, level surface.
 - DO NOT place dispenser into an enclosed space or cabinet.
 - DO NOT operate dispenser in the presence of explosive fumes.
 - Position back and sides of dispenser at least 8 in. (20 cm) from walls to permit free airflow between wall and dispenser. PLEASE NOTE: For optimal performance, it is recommended the back and non-fan-outlet side of the dispenser be placed 12 in. (30 cm) from walls, and the fan-outlet side of the dispenser be placed 19.5 in. (50 cm) from the wall.
 - Always grasp plug and pull straight out from outlet. Never unplug by pulling on power cord.
 - DO NOT use dispenser if cord becomes frayed or otherwise damaged.
 - To protect against electric shock, DO NOT immerse cord, plug, or any other part of dispenser in water or other liquids.
 - Ensure dispenser is unplugged prior to cleaning.
 - Never allow children to dispense hot water without proper and direct supervision. Children should be supervised to ensure they do not play with dispenser. Keep the dispenser and its power cord out of reach of children younger than 8 years old.
 - Service should be performed only by a certified technician.
 - DO NOT damage the refrigerant circuit.
 - If the supply cord is damaged, it must be replaced by the manufacturer, its service agent or similarly qualified persons in order to avoid a hazard.
 - DO NOT immerse dispenser in water or any other liquid.
 - The appliance must not be immersed
 - ALWAYS keep ventilation openings, in the dispenser enclosure or in the built-in structure, clear of obstruction.
 - DO NOT use mechanical devices or other means to accelerate the defrosting process, other than those recommended by the manufacturer.
 - DO NOT store explosive substances such as aerosol cans with a flammable propellant in this dispenser.
 - This dispenser is not suitable for installation in an area where a water jet could be used.
 - Never turn the dispenser upside down or lean it more than 45°.
 - The optimal working environment temperature and humidity level for this dispenser is 50 °F-100.4 °F (10 °C-38 °C) and ≤90% humidity.
- WARNING:** UV light source. Disconnect the electrical supply to the UV radiation BEFORE opening cover.
- UV-LED lamp must be repaired by manufacturer only.
 - UV-LED lamp model no. YB09-950-022, rated DC 24V, 0.17W±20%.
 - Disposal of the UV-LED lamp must be done in accordance with local laws and regulations.
- WARNING:** The appliance must not be cleaned by a water jet.
- WARNING:** Inlet source water must have a TDS of less than 250 ppm. Hardness levels in source water greater than 250 ppm can cause scale buildup, resulting in permanent damage to the hot water tank.

Intended Use

This dispenser is intended to be used in household and similar applications such as:

- Staff kitchen areas in shops, offices, and other working environments
- Farmhouses
- Hotels, motels, and bed-and-breakfast-type environments
- Catering and other similar non-retail applications

The dispenser is not intended for use by persons (including children) with reduced physical, sensory, or mental capabilities, or lack of experience and knowledge, unless they have been given supervision or instruction concerning use of the appliance by a person responsible for their safety.

Product Features

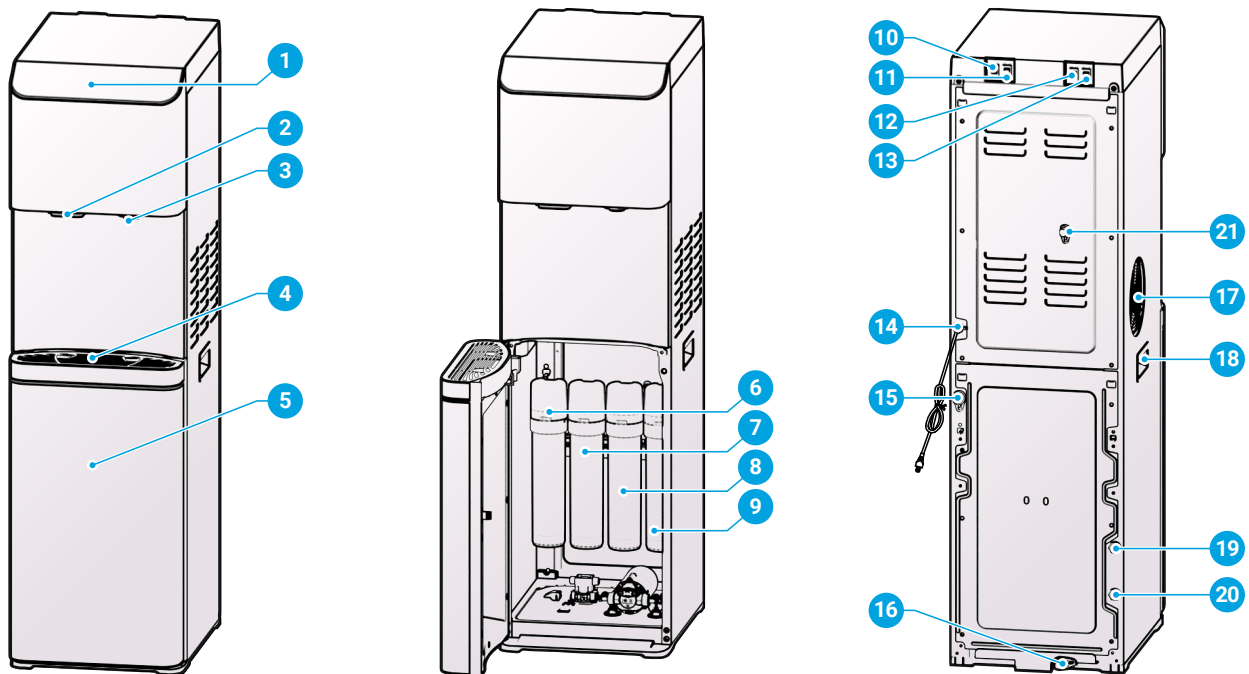

No.	Description
1	Touch panel
2	Ice dispense point
3	Water dispense point
4	Drip tray and grid
5	Cabinet door
6	Sediment filter
7	Pre carbon filter
8	Reverse osmosis (RO) filter
9	Post carbon filter
10	Heating switch
11	Cooling switch

No.	Description
12	Ice-making switch
13	Night light switch
14	Power cord
15	Hot water outlet with cover
16	Drain outlet
17	Fan outlet
18	Handle
19	Water inlet
20	RO water outlet
21	Cold water drain outlet

Touch Panel Description

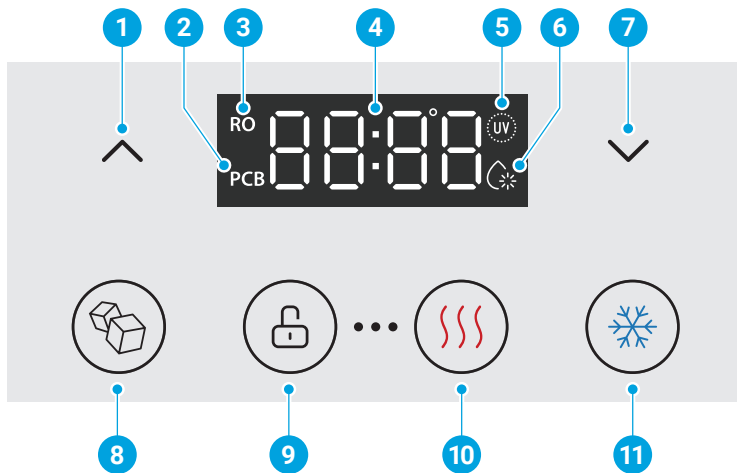

No.	Description
1	Up arrow button
2	Change PCB filter icon
3	Change RO filter icon
4	LED display
5	Self-cleaning UV icon
6	Water production icon
7	Down arrow button
8	Ice button
9	Lock button
10	Hot water button
11	Cold water button

Operational and Technical Specifications

Model: CLPOU720UVRO4IC	
Rated Voltage / Frequency	115 V / 60 Hz
Rated Power	580 W
Heating Power	420 W
Total Current	6A
Cooling Current	1.5 A
Hot Water Tank Volume	0.8 L
Cold Water Tank Volume	3 L
Hot Water Capacity	4 L/h ($\geq 185^\circ\text{F}$ / 85°C)
Cold Water Capacity	3 L/h ($\leq 50^\circ\text{F}$ / 10°C)
Ice Capacity	24.6 lb/day (12 kg/day)

Hot Water Flow Rate	≥ 1.2 L/min
Cold Water Flow Rate	≥ 1.2 L/min
Bullet Ice Production Rate	~9 pieces/12 mins; ~45 pieces/hour
Dimensions (WxHxD)	12.2 x 43.3 x 17.1 in. (31 x 110 x 43.5 cm)
Net Weight	64.37 lb (29.2 kg)
Noise	<55 dB(A)
Operating source water TDS*	≤ 250 ppm

*Please note, hardness levels in source water greater than 250 ppm can cause scale buildup, resulting in permanent damage to the hot water tank.

Package Contents

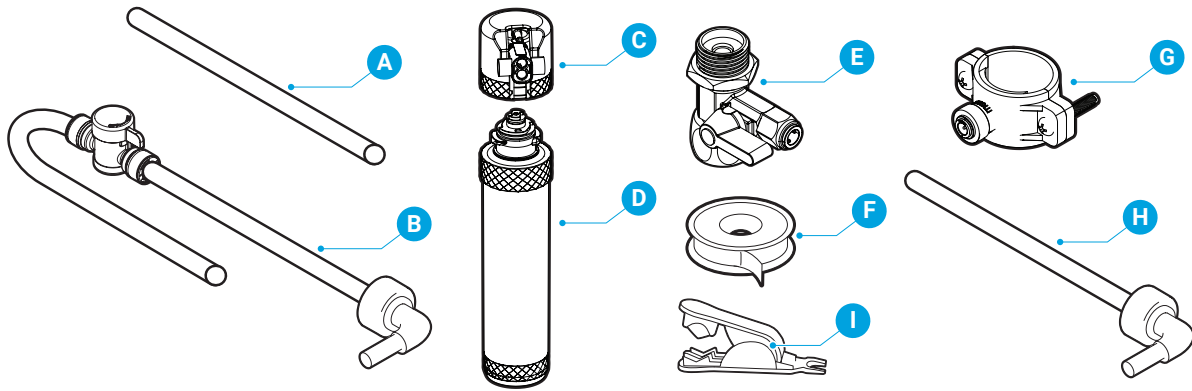

Part	Description	Quantity
A	Filter flushing tube	1
B	Shut-off valve tube (7 ft.)	1
C	Filter housing (for filter flushing)	1
D	Filters	4
E	Feedwater adapter (with extra nut)	1

Part	Description	Quantity
F	Plumber's tape	1
G	Drain saddle with foam gasket	1
H	RO water outlet tube	1
I	Tube cutter	1

Materials Needed



Wrench

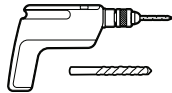

Electric drill with 1/4 in. drill bit

Installation

1. Determine Installation Location

- A. Place the dispenser upright.
- B. Locate the dispenser on a hard, level surface that is out of direct sunlight and near a grounded wall outlet. Allow dispenser to sit for 30 minutes to allow condenser to settle.

NOTE: DO NOT plug in the power cord yet.

- C. Position the left side of the dispenser at least 8 in. (20 cm) from a wall to permit free airflow between the wall and water dispenser.

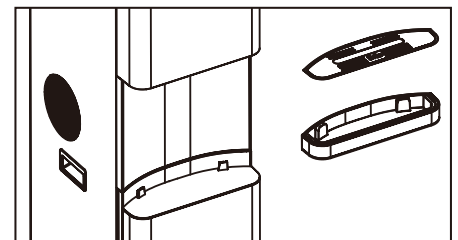

2. Install the Drip Tray and Grid

- A. Remove drip tray and grid from packaging material. Insert grid into drip tray, then slide drip tray into dispenser until it is securely in place.

3. Connect to the Cold Water Supply

CAUTION: DO NOT CONNECT THIS WATER LINE TO A HOT WATER SUPPLY LINE. The water supply to the unit MUST be from the COLD WATER LINE. Using HOT WATER will severely damage your filters.

- A. Turn off the cold water supply, then disconnect the cold water pipe from the cold water supply line.
- B. Connect the feedwater adapter (E) to the cold water supply line.
- C. Connect the cold water pipe to the top of the feedwater adapter (E).

NOTE: An extra adapter nut is included on top of the feedwater adapter (E) to attach to a 3/8 in. or 1/2 in. feed plumbing line.

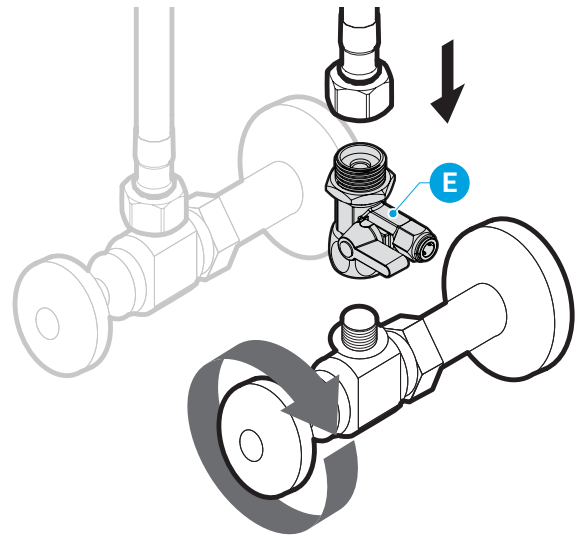

- D. Insert the shut-off valve tube (B) straight into the quick connector piece of the feedwater adapter (E).

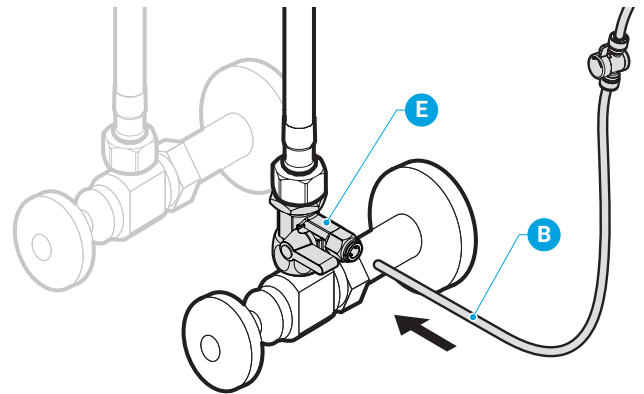

- E. Gently tug on the tube (B) to ensure a secure connection with the feedwater adapter (E).

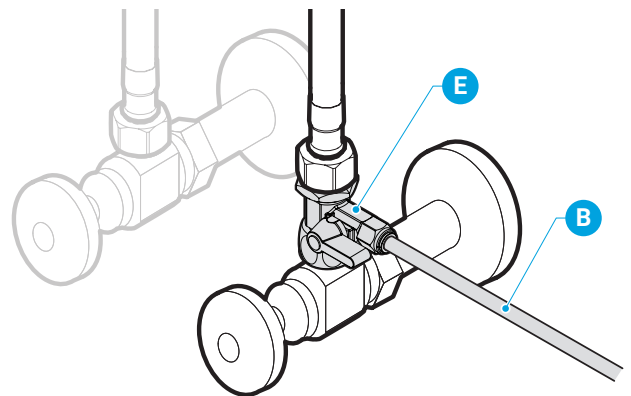

4. Make the Reverse Osmosis Waste Connections

The “RO” filter assembly requires a drain line connection to be installed, which removes rejected water to the sewer. The drain saddle connects the drain line from the dispenser to your drain pipe. The drain saddle is designed to fit around a standard 1.5 in. OD (outer diameter) drain pipe.

- ✓ Always install the drain saddle before the P-trap and on a straight vertical or horizontal section of the pipe.
- ✗ To avoid clogging the drain line with debris, do not install the drain saddle after the drain pipe meets a garbage disposal or dishwasher drain.

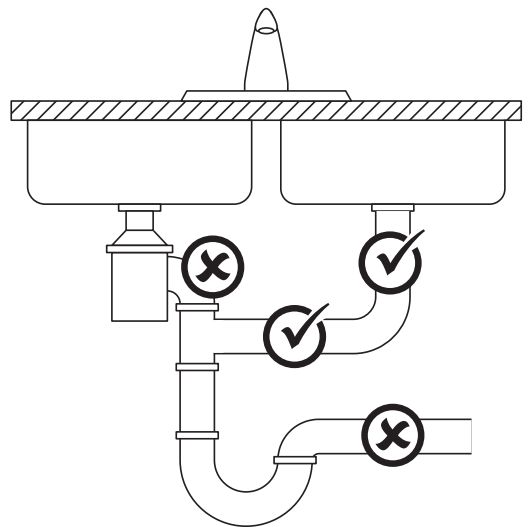

To make the reverse osmosis (RO) drain connections:

- A. Determine the location for your drain saddle (G) and then make a mark on the drain pipe for the opening (1).
- B. Use your drill and a 1/4 in. drill bit to drill a hole at the mark, ensuring you only drill through one side of the drain pipe.
- C. Find the half of the drain saddle (G) with the hole in the center, remove the backing from the foam gasket, align the gasket with the hole on the drain saddle (G), and stick the adhesive side of the gasket to the drain saddle (G).
- D. Position both halves of the drain saddle (G) on the drain pipe with the saddle's opening aligned over the drilled hole, and insert your drill bit through the saddle (G) and drilled hole to ensure proper alignment.
- E. Secure both ends of the drain saddle (G) together using the bolts and nuts, but do not overtighten.
- F. Connect the RO water outlet tube (H) to the drain saddle (G). To prevent water leakage, ensure the RO water outlet tube (H) has been inserted into the pipe 0.6 inches.

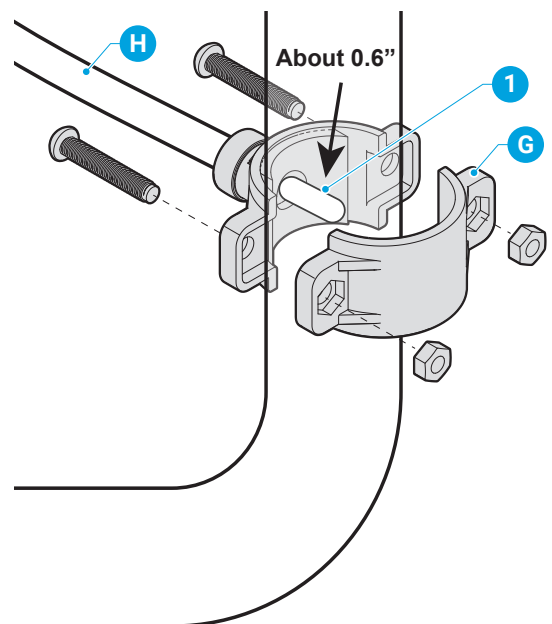

5. Flush the Filters

Follow this procedure each time you replace your filters.

IMPORTANT: Ensure water supply is off before you begin.

IMPORTANT: Flush ONLY the sediment, pre carbon, and post carbon filters. The reverse osmosis (RO) filter should not be flushed.

- A. Connect a filter (D) to the filter housing (C) by twisting the filter (D) clockwise.

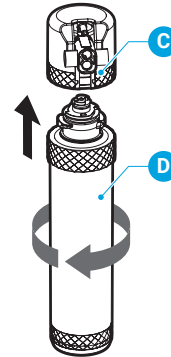

- B. Connect the tip of the shut-off valve tube (B) to the left side of the filter housing (C).
- C. Connect the filter flushing tube (A) to the right side of the filter housing (C) and lay the open end of the filter flushing tube (A) over a sink or receptacle to collect water.

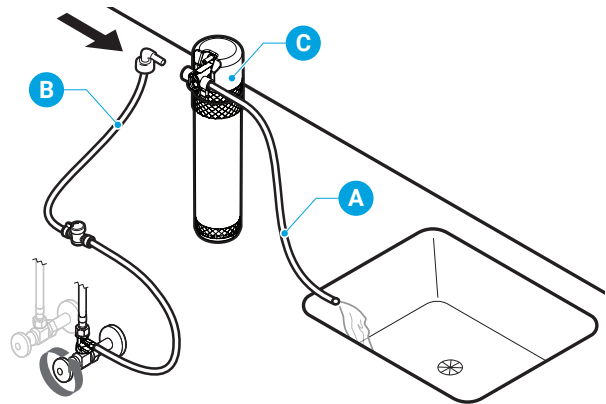

- D. Follow instructions in table below to flush filters.

IMPORTANT: After each filter is flushed, be sure to shut off water supply before disconnecting tubes to flush the next filter.

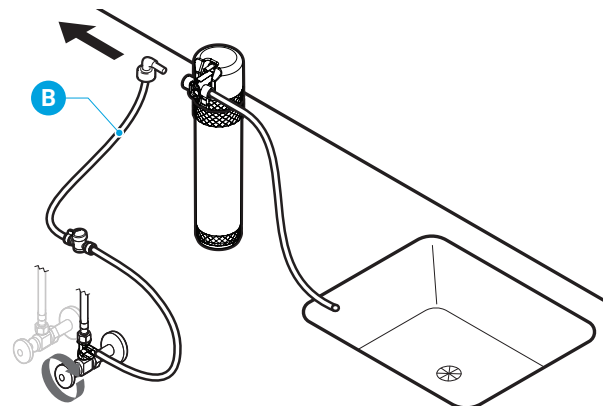

Stage 1: Sediment Filter	Stage 2: Pre Carbon Filter	Stage 3: RO Membrane	Stage 4: Post Carbon Filter
At first, water may appear cloudy. Flush filter for an additional 4 minutes <u>after</u> water runs clear.	At first, water may contain black debris. Flush filter for up to 6 minutes or until water runs clear.	FILTER DOES NOT REQUIRE FLUSHING.	At first, water may contain black debris. Flush filter for up to 4 minutes or until water runs clear.

6. Install the Filters and Complete the Installation

- A.** After flushing, twist each filter (6-9) clockwise into the filter housings located inside the dispenser cabinet. The sediment filter (6) goes on the left, followed by the pre carbon filter (7), RO filter (8), and post carbon filter (9).

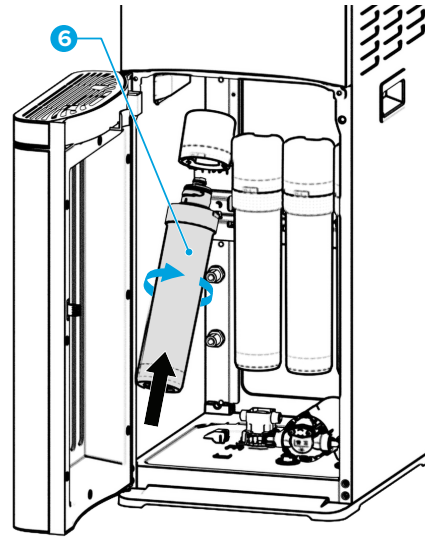

- B.** Remove the safety plug from the water inlet hole on the back of the dispenser by pushing in the inlet hole collar and then gently pulling out the plug. Repeat process with the RO water outlet hole.
- C.** Insert the tip of the RO water outlet tube (H) that extends from the drain saddle (G) into the RO water outlet.
- D.** Insert the tip of the shut-off valve tube (B) into the water inlet hole. Turn on the main water supply and ensure the shut-off valve on the tube is open (parallel to tube).

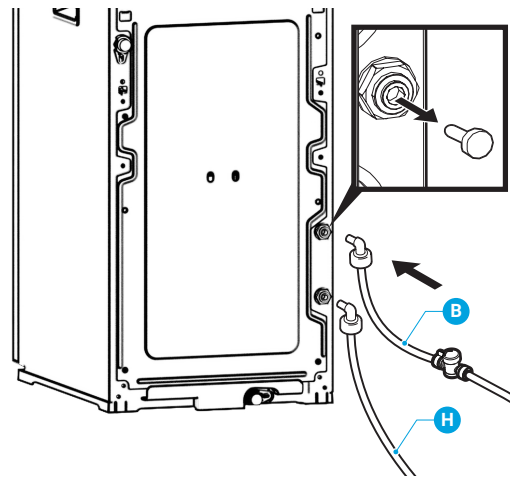

Using the Dispenser

IMPORTANT: This unit has been tested and sanitized prior to packing and shipping. During transit dust and odors can accumulate in the tank lines. Dispense and dispose of at least one quart of water prior to drinking any water.

Turn the Dispenser On/Off

IMPORTANT: Before activating heating, cooling, and ice-making switches, ensure water has filled tanks inside the dispenser in order to prevent dry heating.

1. Plug in dispenser.
2. Allow tanks to fill. During this time, the water production icon (6) will illuminate. When the tanks are full, the icon light turns off.
3. Place a container under the water tap. Press the cold water button and dispense 1 liter of water. Discard water.
4. Place the container under the water tap. Press the hot water button and dispense 1 liter of water. Discard water.
5. Repeat steps 3 and 4 three more times.
6. To power on the cooling system, flip the cooling switch on the back of the dispenser to the On position. The cold water button illuminates in blue, indicating the dispenser is cooling water. The light changes to white when the cooling process is complete.

7. To power on the heating system, flip the heating switch on the back of the dispenser to the On position. The hot water button illuminates in red, indicating the dispenser is heating water. The light changes to white when the heating process is complete.
8. To power on the ice-making system, flip the ice-making switch on the back of the dispenser to the On position. The ice button illuminates in blue, indicating the dispenser is making ice. The light changes to white when the ice-making process is complete.

NOTE: To protect the refrigeration system, the compressor and fan do not begin working until 2 minutes after the power cord has been plugged in.

Set the Time

1. Simultaneously press and hold the up and down arrow buttons for 3 seconds or until the displayed time begins to blink.
2. To adjust hours, press the ice button, then use the up and down arrow buttons to scroll to the correct hour. To adjust minutes, press the cold water button, and use the up and down arrow buttons to scroll to the correct the minutes.
3. Simultaneously press the up and down arrow buttons for 3 seconds when finished. The selected time will be displayed.

Dispense Ice

NOTE: It takes approximately 1 hour after plugging in dispenser and turning on the ice-making switch to create enough ice to be dispensed. It takes approximately 4 hours for the ice storage chamber to completely fill.

1. Place a drinking glass or container under the ice dispense point and press the ice button to dispense ice.
2. Release the button when your container is full.

Dispense Cold Water

NOTE: It takes approximately 1 hour after plugging in dispenser and turning on cooling switch for water to reach its coldest temperature.

1. Place a drinking glass or container under the water dispense point and press the cold water button to dispense cold water.
2. Release the button when your container is full.

Dispense Hot Water

CAUTION: This unit dispenses water at temperatures that can cause severe burns. Avoid direct contact with hot water. Keep children and pets away from the unit while dispensing. Never allow children to dispense hot water without proper and direct supervision. To disable the heating feature, turn the heating switch on the back of the dispenser to the Off position.

NOTE: It takes approximately 15 to 20 minutes after plugging in dispenser and turning on heating switch for water to reach its hottest temperature.

1. The dispenser is equipped with a child-safety feature to prevent inadvertent dispensing of hot water. If you wish to dispense hot water, first place a cup or container beneath the water dispense point. Press the lock button to unlock the hot water button, then release. Press and hold the hot water button to dispense hot water.
2. Release the button when your container is full. Hot water button will automatically lock.

Cleaning and Maintenance

This dispenser runs on a continuous UV cleaning cycle. It works for 40 minutes (UV icon on the display is on), turns off for 140 minutes, and then cycles back on again as long as the dispenser is plugged in and on.

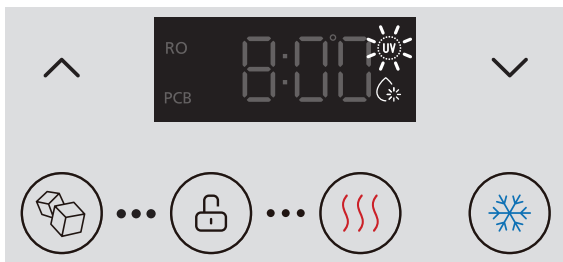

Clean the Reservoirs

The reservoirs should be cleaned every 3 months to remove mineral buildup and optimize dispenser performance.

Gather the following supplies:

- 60–120g (4–8 tbsp.) citric acid crystals
- 2 liters hot water
- 5-liter (1.3 gal.) container or bucket
- Screwdriver
- Clean towel

IMPORTANT: BEFORE beginning the cleaning process, dispense ALL ice from the bin by pressing the ice button. Ice bin **MUST BE** empty before cleaning reservoirs.

1. On the back of the dispenser, switch the red heating, green cooling, black ice making, and blue night light switches to the OFF position, then unplug the dispenser. Carefully move dispenser far enough away from the wall to gain access to the back and to provide ample space for the following steps.
2. Turn the valve on the shut-off valve tube (B) to the OFF position.
3. At the back of the dispenser, place 5-liter container beneath the red hot-water outlet. Using the screwdriver, unscrew the fixing screw of the clear cover over the outlet. Remove the clear cover and set it aside. Pull the red drain plug out and allow hot water to drain into bucket, emptying hot water reservoir. When all hot water has drained out, push drain plug back in, but do not replace drain cover yet. Dispose of water.

CAUTION: Water may be hot.

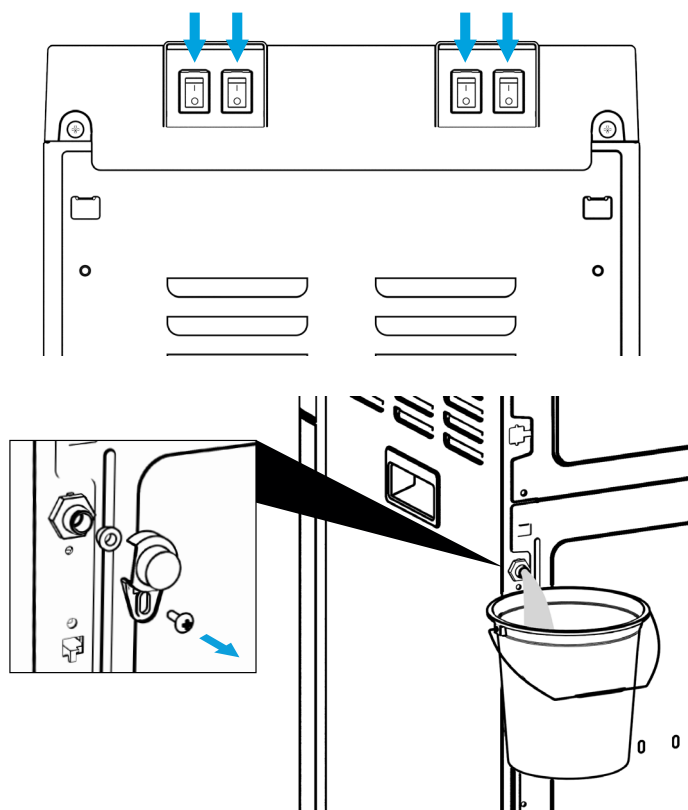

4. To empty the cold water reservoir, remove the screw on the transparent drain cover. Place the small bucket under the drain. Remove the red drain plug and allow water in cold water tank to drain. After the all the water has been drained, reinstall the drain plug. Discard the water.
5. Prepare a cleaning solution by combining citric acid crystals with 2 liters of hot water. Slowly stir the solution so that all the crystals are dissolved.

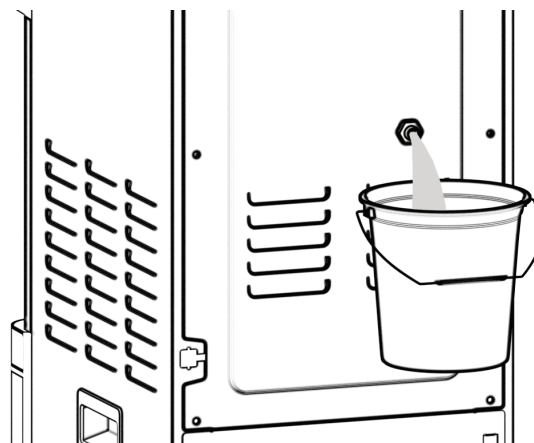

6. At the back of the dispenser, use the screwdriver to remove screws securing the dispenser top. Set screws aside in a safe place. Carefully maneuver the top of the dispenser off. The top will be connected to the dispenser via wires. Carefully allow the top to hang down the side of the dispenser. The cover of the ice bin will now need to be removed. Press the side tabs of the cover to remove the cover. The cover will be attached by wires. Carefully allow cover to hang down side of the dispenser. With ice bin exposed, remove any remaining ice in bin. Slowly pour the cleaning solution into the ice bin.

NOTE: Ice bin has drain holes that will allow solution to filter down into hot and cold water reservoirs.

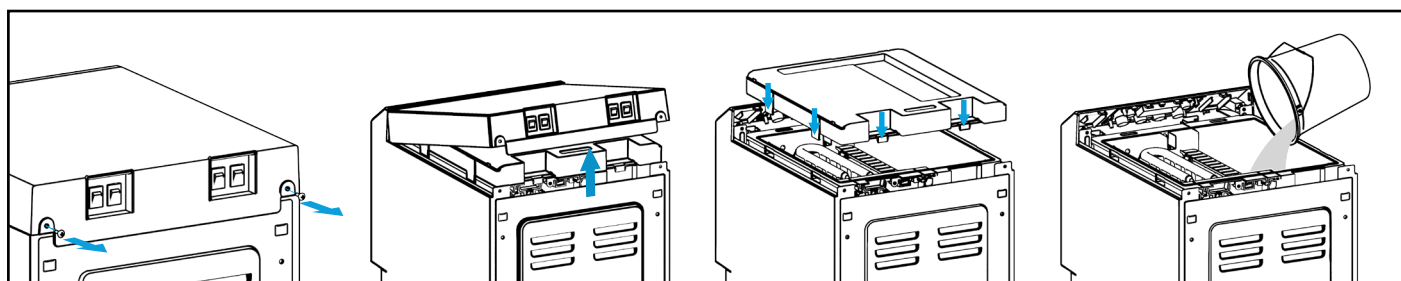

7. After all the cleaning solution has been poured in, snap the cover of the ice bin back into place. Replace the top of the dispenser, then secure it by screwing the 2 screws back into place.
8. Turn the valve on the shut-off valve tube to the ON position. Plug in the dispenser. Wait 40 minutes for the purified water to fill both water reservoirs.
9. Alternately press the hot and cold water buttons to dispense a small amount of water from the water dispense point. Then on the back of the dispenser, switch the green cooling switch to the ON position. Wait 30 minutes for the cleaning cycle to complete. After 30 minutes, unplug the dispenser. Drain the solution following the instructions in Steps 3 and 4. Plug the dispenser back in and allow the reservoirs to refill with fresh water.
10. Repeat Step 9 three more times to flush the water reservoirs with fresh water. If lingering odors or tastes persist, repeat the cleaning process.
11. Once you're finished, wipe up any spilled water, reinstall the clear cover over the hot water outlet, and move dispenser back into place.

Filter Replacement Schedule

Filter Type	Model No.	Replacement Schedule	Function
Sediment	NFMPP5M	6-12 months or 950 gallons	Performs coarse filtration of inlet water, removing sand, rust, dirt, and other suspended solids.
Pre Carbon	NFMGAC	6-12 months or 950 gallons	Removes chlorine, and other unpleasant tastes and odors.
Reverse Osmosis (RO)	NFMRO75GPD	6-12 months or 1,900 gallons	Removes contaminants, including lead, arsenic, fluoride, and TDS.
Post Carbon	NFMCTO5MS4	6-12 months or 950 gallons	Performs final polish, removing any residual impurities.

Replace the Filters

IMPORTANT: Only replace the filters with new filters designed for this dispenser. Any other type of filter will damage the machine and void any warranty.

When the PCB (2) and RO (3) filter indicator lights steadily illuminate and the dispenser beeps, the filters have expired and must be replaced immediately. To replace do the following:

1. Shut off the water supply.
2. To flush your new filters, follow the instructions under “Flush the Filters.”
3. Remove the expired filters and replace with new filters. Ensure filters are installed as follows, from left to right: sediment, pre carbon, reverse osmosis, and post carbon.
4. After replacing the filters, press the up arrow (1) for approximately 3 seconds to reset the filter indicator lights and turn off the beeping.

Filter Specifications

Sediment Filter

(Sediment, Dirt, and Rust Removal)

Filter Capacity	950 Gallons
Flow Rate	0.8 GPM
Suggested PSI	14.5 - 58 psi
Temperature	33 - 100 °F

Pre Carbon Filter

(Chlorine, Taste, and Odor Reduction)

Filter Capacity	950 Gallons
Flow Rate	0.8 GPM
Suggested PSI	14.5 - 58 psi
Temperature	33 - 100 °F

RO Filter

(Heavy Metal and TDS Removal)

Filter Capacity	1,900 Gallons
Flow Rate	0.035 GPM
Suggested PSI	58 - 116 psi
Temperature	33 - 100 °F

Post Carbon Filter

(Final Polish)

Filter Capacity	950 Gallons
Flow Rate	0.8 GPM
Suggested PSI	14.5 - 58 psi
Temperature	33 - 100 °F

Care and Maintenance

- Keep this dispenser in a dry and cool place and avoid direct sunshine.
- Ensure the back of the dispenser is at least 8 in. (20 cm) away from the wall.
- Never put the dispenser on paper or foam, which may store water and then cause creepage. Never put anything flammable beside this machine.
- Do not use the dispenser outdoors or in a place that can be splashed by water.
- If the dispenser is not in use for longer than a 24-hour period, turn off the heating, cooling, and ice-making switches to save power, and drain any remaining water and dispense any remaining ice.
- Empty and clean drip tray and grid as needed.
- If the water supply is cut off, shut off the water supply, dispense all ice, and turn the dispenser off. When the water supply is back on, re-open the water supply to the dispenser, turn the dispenser on, and allow the dispenser to run in order to discharge sediment.

Troubleshooting

Problem	Solution
The cold water is not cold	<ul style="list-style-type: none"> • It takes approximately one hour after setup to dispense cold water. • Make sure the power cord is properly connected to a working outlet. • Ensure your dispenser's back and non-fan-outlet sides are 12 in. (30 cm) from walls, and the fan-outlet side is 19.5 in. (50 cm) from the wall. • Make sure green power switch on back of dispenser is On.
There is no ice	<ul style="list-style-type: none"> • It takes approximately one hour after setup to dispense ice. • Make sure the power cord is properly connected to a working outlet. • Ensure your dispenser's back and non-fan-outlet sides are 12 in. (30 cm) from walls, and the fan-outlet side is 19.5 in. (50 cm) from the wall. • Make sure black ice-making switch on back of dispenser is On.
The hot water is not hot	<ul style="list-style-type: none"> • It takes 15-20 minutes after setup to dispense hot water. • Make sure the power cord is properly connected to a working outlet. • Make sure red heating switch on back of dispenser is On.
Water flow is slow	<ul style="list-style-type: none"> • Water output may slow or decrease if there has been continuous dispensing. Allow tanks to refill before dispensing.
The night light is not working	<ul style="list-style-type: none"> • Make sure the power cord is properly connected to a working outlet. • Make sure the blue night light switch on back of dispenser is On.
The dispenser is noisy	<ul style="list-style-type: none"> • Ensure the dispenser is located on a sturdy, level surface. • The heating tube may be generating a slight noise. This is normal.
There is water leakage	<ul style="list-style-type: none"> • If E0 appears in the LED display, a leak was detected. • The tubing is not connected properly. Check all water connections and tubes to ensure proper connections. • The water and/or PE tubes have burst. Turn off water supply and replace immediately.
The dispenser is not dispensing water	<ul style="list-style-type: none"> • There may be air blockage in the tubing. Press the hot and cold water buttons until water begins to dispense.

Warranty

Brio (“Vendor”) warrants to the original purchaser of the Brio Water Cooler (the “Product”), and to no other person, that if the Product is assembled and operated in accordance with the printed instructions accompanying it, then for a period of one (1) year from the date of purchase, all parts in the Product shall be free from defects in material and workmanship. This Limited Warranty shall be limited to repair or replacement of parts, which prove defective under normal use and service and which Vendor shall determine in its reasonable discretion upon examination to be defective. To take advantage of this Limited Warranty, please follow these steps:

1. Please retain your sales slip or invoice, as Vendor may require reasonable proof of your date of purchase.
2. Contact Vendor’s Customer Service Department using the contact information listed below.
3. Return parts to Vendor, per Vendor’s instructions, at your cost and expense.
4. Upon receipt by Vendor, Vendor shall advise you in writing whether a defect covered by this Limited Warranty exists in any returned part and whether your claim has been approved or denied.
5. Upon Vendor’s approval of your claim, Vendor will replace such defective part without charge to you.

WHAT THIS LIMITED WARRANTY DOES NOT COVER: This Limited Warranty does not cover any failures or operating difficulties of the Product due to accident, abuse, misuse, alteration, misapplication, improper installation or improper maintenance or service by you or any third party, or failure to perform normal and routine maintenance on the Product, as set out in the User’s Manual. In addition, this Limited Warranty does not cover damages to the finish, such as scratches, dents, discoloration or rust after purchase.

This Limited Warranty is the only express warranty given on the Product and is in lieu of all other express warranties. Vendor disclaims all warranties for products that are purchased from seller other than authorized retailers or distributors. THIS LIMITED WARRANTY RESTRICTS THE DURATION OF ANY AND ALL IMPLIED WARRANTIES, INCLUDING WITHOUT LIMITATION, THE IMPLIED WARRANTY OF MERCHANTABILITY AND FITNESS FOR A PARTICULAR PURPOSE TO THE ONE (1) YEAR TERM OF THIS LIMITED WARRANTY. UPON THE EXPIRATION OF THE ONE (1) YEAR TERM OF THIS LIMITED WARRANTY, VENDOR DISCLAIMS ANY AND ALL IMPLIED WARRANTIES, INCLUDING WITHOUT LIMITATION THE IMPLIED WARRANTIES OF MERCHANTABILITY AND FITNESS FOR A PARTICULAR PURPOSE, THE PRODUCT BEING THUS SOLD AS-IS, WITH ALL FAULTS. FURTHER, VENDOR SHALL HAVE NO LIABILITY WHATSOEVER TO PURCHASER OR ANY THIRD PARTY FOR ANY SPECIAL, INDIRECT, PUNITIVE, INCIDENTAL, OR CONSEQUENTIAL DAMAGES. OTHER THAN THIS LIMITED WARRANTY, THERE ARE NO WARRANTIES WHICH EXTEND BEYOND THE DESCRIPTION ON THE FACE HEREOF. Vendor assumes no responsibility for any defects caused by third parties. This Limited Warranty gives you specific legal rights, and you may have other rights which vary from state to state. State law may also override statements in this Limited Warranty regarding the restriction on the duration of implied warranties. Some jurisdictions do not allow exclusion or limitation of special, incidental or consequential damages, or limitations on how long a warranty lasts, so the above exclusion and limitations may not apply to you.

Brio[®]

www.briowater.com